

INSTALLATION, OPERATION AND MAINTENANCE MANUAL

THREE WAY FLOATING BALL VALVE

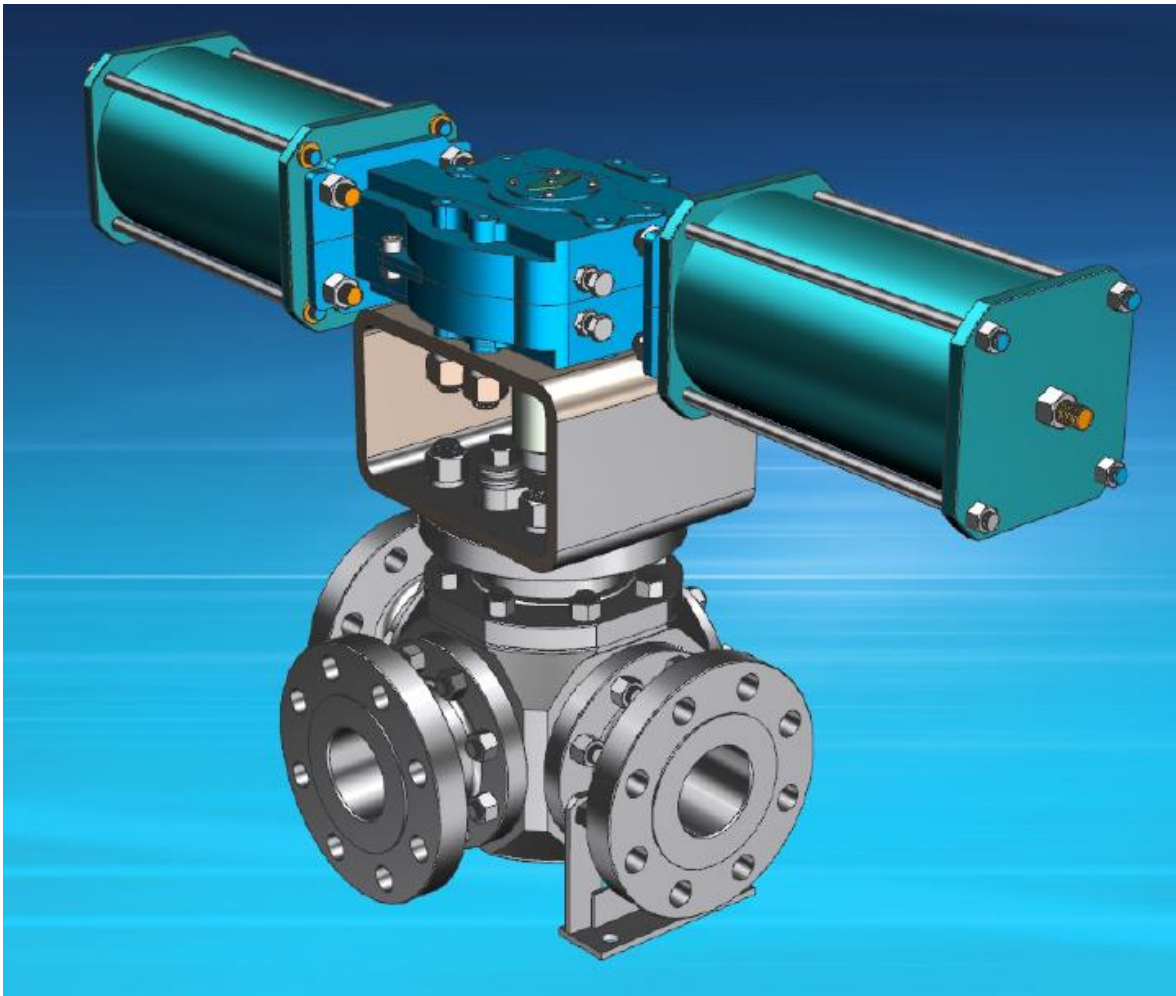



TABLE OF CONTENTS

TYPICAL CONFIGURATION 3

FOREWORD..... 4

1. ENDUSER INSTRUCTION 4

2. VALVE TRANSPORTATION AND STORAGE 5

2.1 TRANSPORTATION..... 5

2.2 STORAGE 7

3. VALVE INSTALLATION 7

3.1 INSPECTION BEFORE INSTALLATION 8

3.2INSTALLATION 8

4. VALVE OPERATION 11

5. VALVE MAINTENANCE 14

6. DETAILED DISASSEMBLY AND ASSEMBLY 16

6.1 FLOATING BALL VALVE DISASSEMBLY 16

6.2 FLOATING BALL VALVE ASSEMBLY..... 16

7. TROUBLESHOOTING..... 18

8. WARRANTY AND SERVICE 19

8.1 VALVE WARRANTY PERIOD 19

8.2 SERVICE..... 19

APPENDIX I – INSTALLATION REQUIREMENTS 20

TYPICAL CONFIGURATION

VALVE DETAILS –THREE WAY FLOATING BALL VALVE

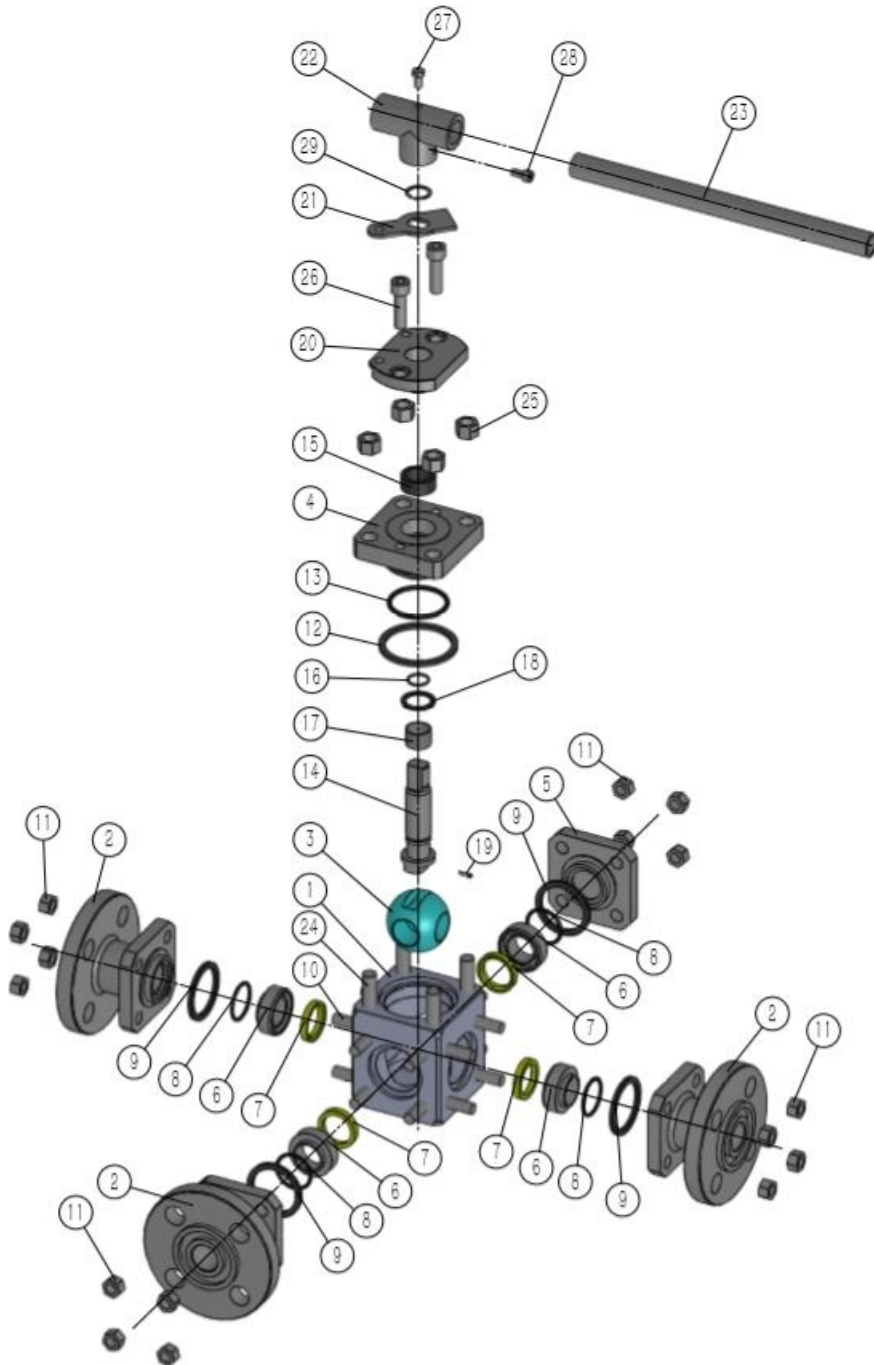

No.	Description
1	Body
2	End Cap
3	Ball
4	Bonnet
5	Rear Cover
6	Seat Retainer
7	Seat Insert
8	O-Ring, Seat Retainer
9	Gasket, Body
10	Stud
11	Nut
12	Gasket, Bonnet
13	O-Ring, Bonnet
14	Stem
15	Packing
16	O-Ring, Stem
17	Bearing, Stem
18	Thrust Washer
19	Anti-static Device
20	Packing Gland
21	Stop Plate
22	Handle Adapter
23	Handle
24	Stud
25	Nut
26	Bolt
27	Bolt
28	Bolt
29	Snap Ring



FOREWORD

Personal safety and long-term ownership of your DHV Three-Way Ball Valve is the most important matter in reviewing our Installation, Operation & Maintenance Manual. This manual will provide all the necessary safety guidelines for our valve including information for the valve transportation, storage, installation, operation and maintenance. Please read carefully before installing or servicing the valve.

DHV provides general guidelines in this manual, and cannot provide specific data and warnings for all possible applications. The purchaser/end user must therefore assume responsibility for proper valve selection, sizing, installation, operation, and maintenance of DHV valve products. The purchaser/end user should read and understand this document and any instructions provided with the product, and conduct training with its employees and contractors to ensure they are aware of the proper and safe use of DHV valve products in connection with the specific application.

1. ENDUSER INSTRUCTION

Personnel safety is always the most important factor in the transportation, storage, installation, operation and maintenance of any valve. DHV valves are designed to meet the customer's order requirements and specifications. DHV disclaims all responsibility for problems that may be caused by applications other than the specified use. Valve service pressure/temperature information is detailed on the valve name plate. When selecting a valve, always consider the application, service and temperature for the intended service. Select the applicable valve material for anti-corrosion and anti-abrasive service. For safety of personnel and plant/environment: Prior to conducting any service to the valve, ensure the valve is not under pressure, properly vented, and drained before servicing. For all electric, hydraulic or pneumatic actuated valves, all power connections to the valve/actuator must be turned off before performing any maintenance and service. When performing any operation, maintenance or service, personal protective equipment should be used, such as protective clothing, oxygen masks, safety glasses, work gloves, etc. DHV will not be responsible for any loss or expense resulting from the failure of equipment, damage to any property, or death or injury to any person resulting in whole or in part from repairs or modification performed by other than authorized DHV personnel. Such unauthorized repairs shall also serve to terminate any contractual or other warranty, if any, on the equipment and may result in equipment no longer meeting applicable requirements.



2. VALVE TRANSPORTATION AND STORAGE

2.1 TRANSPORTATION

1. Valves should remain in the open position to prevent damage to the seating surface during shipping and handling. Each valve should be securely packaged either on a pallet or in a crate to avoid any damage during shipping.
2. Use the proper hoisting equipment to transport the valve, especially during lifting or lowering the valve. Special attention to personnel safety and the care of the valve should be made when transporting the valve. Avoid impacting or striking the valve during transportation. Lay the valve on a clean flat surface; make sure to avoid laying the valve on the flange face. Ensure there is adequate clearance around the valve for proper operation and maintenance.

When lifting the valve, use the valve lifting lug; if the valve does not come with lifting lug, use an appropriate sized sling to go around the body flange neck to lift the valve. Never lift the valve by the gear/neck area or the flange holes. See Fig 1-A & 1-B below that illustrates correct and incorrect valve handling.

3. During transportation, ensure the valve paint, name plate and flange sealing surfaces are fully protected. Do not drag the valve on the floor, nor put the valve flange sealing face on the floor.
4. For those valves not required to be immediately installed, do not open the end flange protective covers. Ensure the valves are stored in a safe clean environment and are protected from rain and dust.

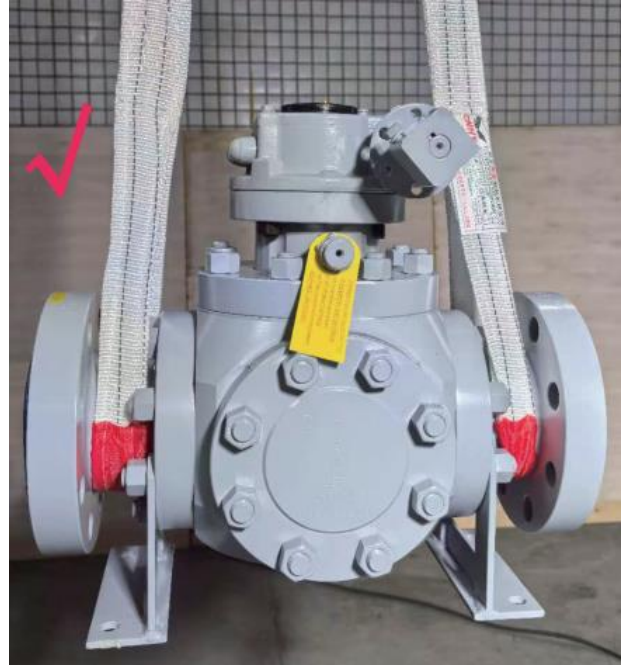
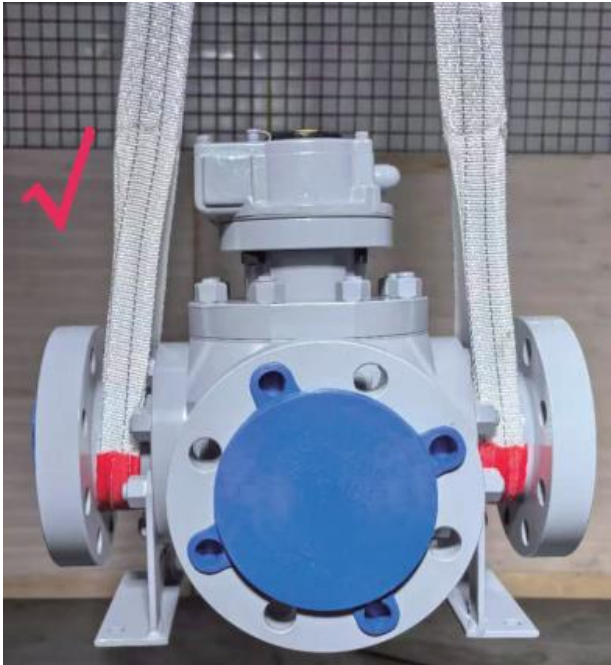

Figure 1-A Correct Valve Handling

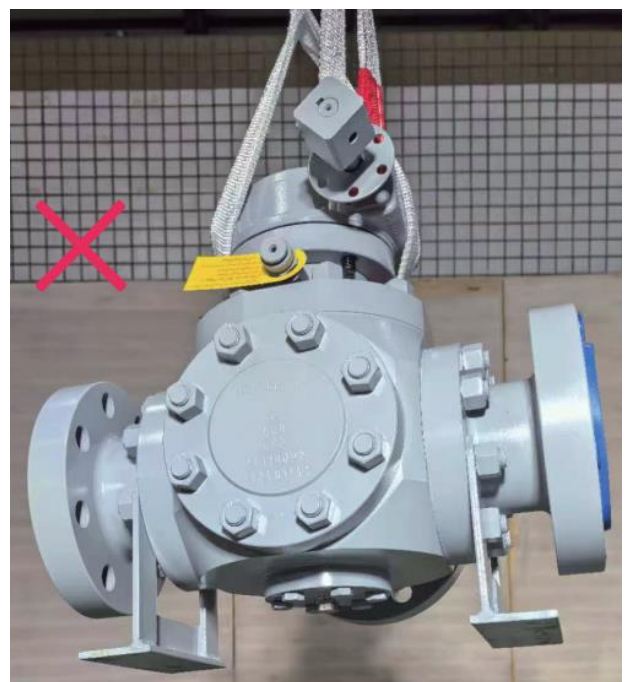
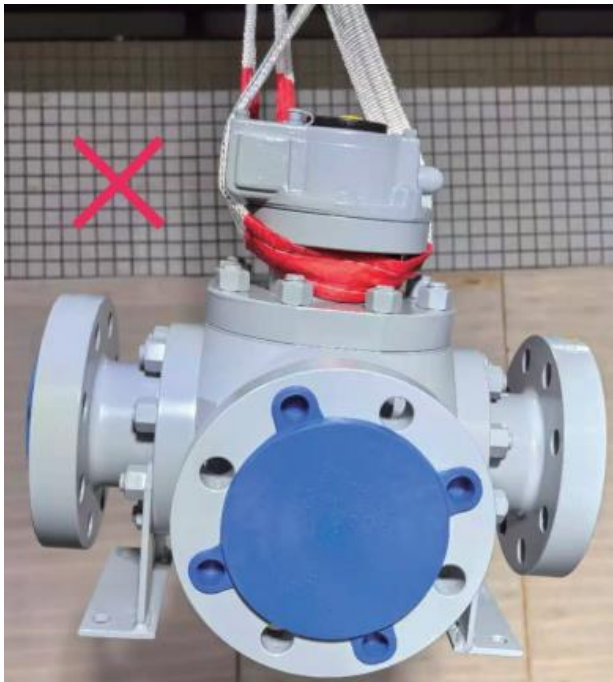

Figure 1-B Incorrect Valve Handling

2.2 STORAGE

1. Valves should be stored in the open position. Valve ports and flange serration surfaces should be kept sealed with protective flange covers.
2. Valves should be stored in a dust free, low humidity and well ventilated room, not in direct contact to the floor. If possible, the valves shall be kept in the original packing box. If valves have to be stored outdoors, keep the valve in the original crate or shipping container. Ensure the valve packaging is stored on raised blocking to avoid moisture damage. Protective covering should be used for protection against dust and rain.
3. Valves should never be stacked on top of each other, to avoid any valve distortion which may affect valve performance and cause personnel injury.
4. Valves that have been stored for an extended period of time should be cleaned and inspected prior to installation. Inspect the sealing surface to ensure it is clean and free of any debris or damage.
5. Do not expose the valve to any corrosive environment as this may cause damage to the valve components.

3. VALVE INSTALLATION

- Review all documentation to fully understand the valve and related information that will provide safe installation and a long service life for your valve.
- Valve information can be found on the valve body, and the nameplate. Fig 2 is a typical nameplate. Reference the information on our nameplate for ordering replacement parts, or when making inquiries about your valve’s operation or maintenance needs.
- Valve ends should have a protective cover to protect the valve port from any foreign particles and dust which will damage the ball and seat sealing surfaces.

 DHV INDUSTRIES INC. FLOATING BALL VALVE LOW EMISSION	SIZE: 3 (DN80)	CLASS: 600 (PN100)	1480 psi at -50 °F	1180 psi at 300 °F
	BODY: LF2	STEM: A182 F51	120.1 bar at -46 °C	81.4 bar at 150 °C
	BALL: A182 F316	FIG NO.: B0603F37-BS	API 608/B16.34 API 6FA NACE MR0175	
	SEAT: RPTFE	S/N NO.:	MFG DATE:	TYPE: L-Three-way

SIZE	Nominal valve size
CLASS	API class designation
FIG NO.	See the DHV Catalog
S/N NO.	Serial number
BODY	Body material designation
STEM	Stem material designation
BALL	Ball material designation
SEAT	Seat material designation
psi at °F	Operating pressure
DATE	Valve manufacturing date

Figure 2 Typical Valve Nameplate Information



3.1 INSPECTION BEFORE INSTALLATION

3.1.1 Before installation, check the valve nameplate and valve body information to ensure the valve is suitable for the intended service.

3.1.2 Before installation, remove the flange cover and the protective film on the flange sealing face, inspect the ports and the flange sealing surface, remove any dirt with a clean soft cloth, use an anti-corrosive cleaning liquid to clean if necessary, and never use any other chemical products.

3.1.3 Inspect the flange gasket (including ring gasket) sealing surface and ensure it is in acceptable condition for installation.

3.1.4 After cleaning the valve and before installation, open and close the valve one time. Ensure the valve cycles smoothly. If abnormal operation is experienced, stop the operation and inspect the valve internals for any obstructions that may be preventing normal operation.

3.1.5 After successfully cycling and assuring the proper operation of the valve, return the valve to the open position and ensure the valve sealing surfaces are protected until installation is complete.

3.2 INSTALLATION

3.2.1 Position the valve into the pipe or the flange connection; ensure that any stresses caused by improper pipe alignment are relieved. Valves are not intended to be a means of aligning improperly fitted pipe.

3.2.2 Install the valve using qualified piping standards and practices. Valves marked with flow direction must be installed in line with the piping flow.

3.2.3 The recommended orientation for ball valves is upright with the valve in a horizontal line. The valve may be installed in other orientations; however, any deviation from recommended horizontal position may compromise proper valve operation and void the warranty.

FLANGE ENDS:

- Select the proper gasket (including ring gasket) to install, line up the bolt holes between the valve flange and pipeline flange, then install the bolts and nuts and tighten to the accepted piping and bolting standards. The bolt threads should be lubricated first for ease of bolting.
- Use an appropriate sized torque wrench when tightening the bolt/nut, to avoid flange deformation. Please follow Fig 3 and Table 1 for bolting sequence and bolting torque. If the bolting quantity is different from the chart shown, please follow the same principle to get a new sequence to follow.
- For large diameter valves, the valve must be properly and safely supported during installation. After installation is completed, valve supports should be moved to the bottom of the valve flanges.
- After valve installation is complete, recheck and tighten the bolts including the gland bolts as necessary to the values provided in Table1 & Figure 3



- It is recommended that the tightness of the joint bolt tension and gland bolts be inspected at least yearly. Refer to Table 1 & Figure 3



DURING INSTALLATION, IF VALVE IS NOT IN LINE WITH THE PIPELINE, FLANGE FACES ARE NOT PARALLEL TO EACH OTHER, OR BOLTING TORQUE IS NOT UNIFORM, VALVE LEAKAGE MAY BE EXPERIENCED.

Table 1 Bolting Tightening Torque Chart

Stud Size (Inch)	Measurement: Newton-meters N·m Tolerance: +/- 10%						
	(Conversion: 1 ft·lb= 1.36 N·m 1 N·m = .74 ft·lb)						
	B7M/L7M	B7/L7	B8 (I)/ B8M(I)	B8M (II)	B8 (II)	B8MLCuN	B16
5/16-18UNC	21	27	8	25	26	9	28
3/8-16UNC	36	47	13	43	45	16	48
1/2-13UNC	85	111	32	101	107	37	112
9/16-12UNC	121	158	45	144	152	53	160
5/8-11UNC	165	217	62	197	208	72	218
3/4-10UNC	289	378	108	344	362	126	380
7/8-9UNC	459	601	171	459	-	200	605
1-8UNC	683	894	255	683	-	298	901
1-1/8-8UN	992	1298	370	811	-	433	1308
1-1/4-8UN	1381	1807	515	1130	-	602	1820
1-3/8-8UN	1860	2435	693	1167	-	812	2452
1-1/2-8UN	2438	3192	909	1530	-	1064	3214
1-5/8-8UN	3126	4092	1165	-	-	1364	4120
1-3/4-8UN	3931	5146	1465	-	-	1715	5182
1-7/8-8UN	4863	6367	1813	-	-	2122	6411
2-8UN	5933	7767	2211	-	-	2589	7820
2-1/4-8UN	8519	11152	3175	-	-	3717	11229
2-1/2-8UN	11764	15400	4385	-	-	5133	15507
2-3/4-8UN	15742	18747	5867	-	-	6869	18747
3-8UN	20528	24447	7651	-	-	8958	24447



Table 1 Bolting Tightening Torque Chart (cont.)

Stud Size (Metric)	Measurement: Newton-meters N·m Tolerance: +/- 10%						
	(Conversion: 1 ft·lb= 1.36 N·m 1 N·m = .74 ft·lb)						
	B7M/L7M	B7/L7	B8 (I)/ B8M(I)	B8M (II)	B8 (II)	B8MLCuN	B16
M10	43	56	16	51	54	19	56
M12	73	96	27	87	92	32	96
M16	175	230	66	209	221	77	232
M20	338	443	126	338	424	148	446
M24	578	757	215	578	-	252	762
M30	1134	1484	422	928	-	495	1495
M36	1964	2572	732	1232	-	857	2589
M42	3125	4091	1165	1960	-	1364	4119

Figure 3 Bolt Tightening Sequence

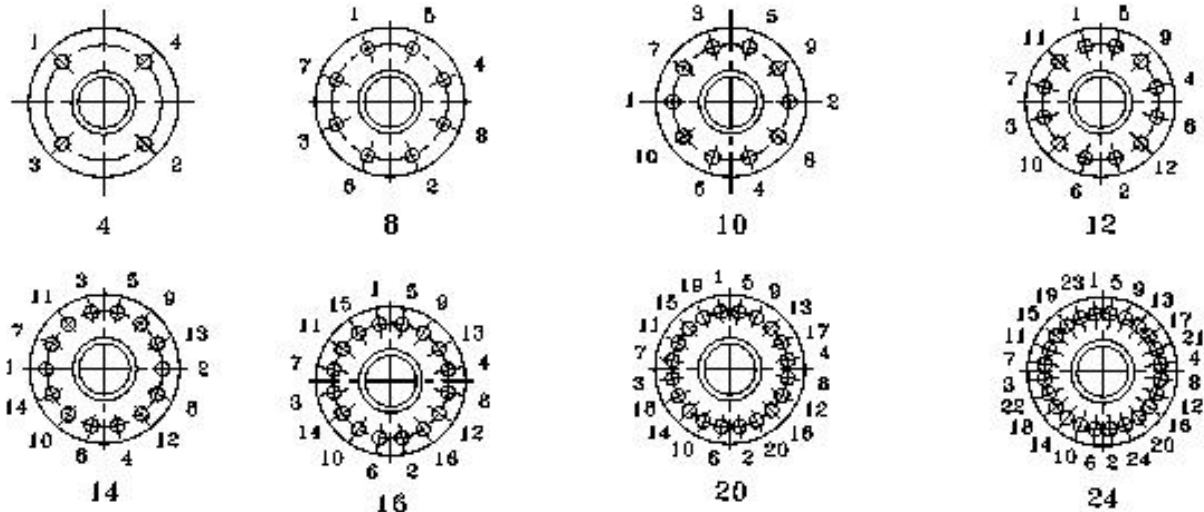

WELD ENDS:

- Weld ends must be kept clean with no burrs, oil, dirt or foreign objects.
- The valve end and pipe end must be in proper alignment for effective welding.
- Follow the approved WPS to perform the welding. Ensure that the temperature of the body/seats area does not exceed 200 °F, verify this temperature with a Tempil stick; welding too close to the seat/sealing area will cause area distortion. Protect the valve port area to prevent welding slag and foreign matter from entering the valve.
- After welding, use approved and proper Non-Destructive Testing (NDT) method to check the welds; clean the welds thoroughly, and then perform local heat treatment if required.
- When installation is complete, prior to system testing and start-up, clean the valve by flushing the line of debris and other materials that may have accumulated inside the valve and in the valve seating area and surfaces during construction. When flushing the valve, open the valve fully, flush for a determined time based on line size. Close the valve to allow the fluid to fill the line; operate the valve to the half open and half closed position repeatedly, this action allows the fluid to build up within the valve assisting in flushing heavier debris from the valve. Fully close the valve, if seat leakage is noted after flushing, repeat flushing procedure. If leakage from the seat is still evident, the seating surface maybe damaged and need repair. If the valve is equipped with seat injection, the seats should be charged with a valve lubricant to displace any residual fluids or moisture in the seal areas of the valve.



DURING WELDING, THE TEMPERATURE NEAR THE VALVE SEAT INSERT AND ANY O-RING AREAS SHOULD NEVER EXCEED 94°C/200°F. A TEMPERATURE INDICATING DEVICE SHOULD BE USED TO MONITOR THE TEMPERATURE DURING THE WELDING. THIS ALSO APPLIES TO POST WELD HEAT TREATMENT.

4. VALVE OPERATION

- To assure maximum valve performance, only use a valve that is suitable for the rated pressure/temperature and corrosive environment.
- For your safety and normal operation, please read the following valve operation procedures:

4.1 The valve must be kept either in the fully open or fully closed position. Never throttle or leave the valve at the half-open position as erosion of the ball and seating surface may occur and damage will result.

4.2 The position marking of the ball hole of the three-way ball valve is as follows.

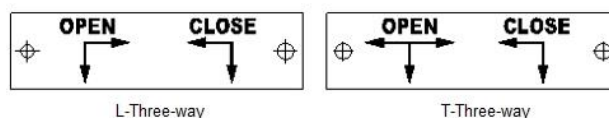

4.3 There are position stops for the valve at the fully open and fully closed position. When the valve lever or hand wheel will not rotate any further it means the valve is already at the fully open or fully closed position. The open/close stroke is 90°.

4.4 L-port three-way ball valve. If a 180-degree opening and closing is required, please specify this requirement before placing the order.

L-Port 3-Way Ball Valve Flow Patterns

L-Port 90-Degree or Two-Position Flow Pattern

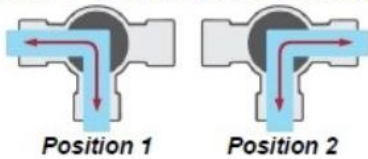

L-Port 180-Degree or Three-Position Flow Pattern



4.5 T-port three-way ball valve. If a 180-degree opening and closing is required, please specify this requirement before placing the order.

T-Port 90-Degree or Two-Position Valve Flow Patterns

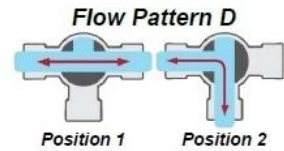
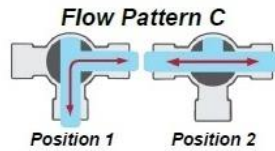
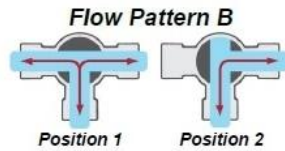
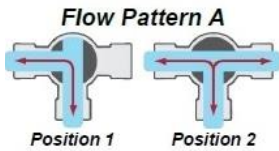

T-Port 180-Degree or Three-Position Valve Flow Patterns

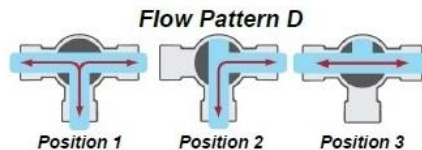
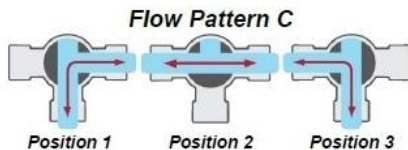
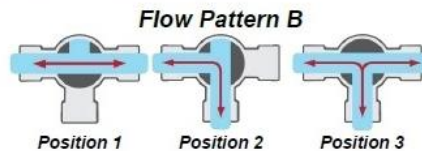

4.6 Never operate the valve without authorization and a full understanding of the safe operation procedures, inspections and proper handling instructions.

Table 2



When Torque Wrenches are Not Available or Suitable, The Use of Standard Wrenches and Guidelines Will Apply to Avoid Over Torque or Damage to the Valve.

BOLT SIZE	LENGTH OF WRENCH (inches)
3/8"	5"
1/2"	6"
9/16"	9"
5/8"	12"
3/4"	18"
7/8"	24"
1"	30"
1-1/8"	36"
1-1/4"	42"

5. VALVE MAINTENANCE

Valves should be inspected regularly during operation and any findings should receive immediate attention in order to avoid any further damage to the valve or the system. Regular inspection and maintenance should be scheduled at a minimum of twice per year, or more often if required.

5.1 In less corrosive environments, it is suggested to check the valve body thickness every six months. In more corrosive environments, it should be checked every three months. If the measured wall thickness is less than specified in ASME B16.34, the valve should be replaced immediately.

5.2 The valve seat pocket area is a primary area where the operation of the valve can be affected by debris and contaminants within the line. To ensure the seat's operational movement within the valve, it is recommended that the valve seat pockets be cleaned routinely with a product designed for the valve trim and the service needs. Routine service can vary depending on the severity of the operating service of the valve. Once the valve is in service, it is recommended to use a seat cleaning detergent or light lubricant to clean the seat sealing surface of any debris which may have been introduced into the piping or the valve at the time of installation. Recommended cleaning of the valve seats should be at minimum every six months; valves which are operated more often should be every three months to maintain and ensure the integrity of the seat's seal.

5.3 Before removing the valve from a pipeline, always mark the connecting flanges for proper fitment and valve flow direction.

5.4 After any valve repair, reference Table 1 for proper bolt torque to assemble the valve.

5.4.1 Over torquing can cause deformation of the body/bonnet flange causing leakage. Failure to properly follow the tightening sequence will result in the gasket not being compressed evenly, resulting in gasket leakage.

5.4.2 **WARNING:** Never use impact devices to tighten the bolting on the body/bonnet connections. Use suitable designed mechanical devices such as hand torque wrenches for tightening and refer to Table 1. Torque wrenches and standard wrenches may be used in combination when performing tightening sequences.

5.5 To assure the valve is sealing properly, perform the required pressure testing per recognized and applicable design standards.

5.6 During maintenance or servicing of the valve, all replacement parts must be the same as the original specification (parts dimensions and materials). End user may also purchase the spare parts such as packing, gaskets, bolts/nuts etc. when ordering the valve. With the new packing, gasket or bolt/nuts installed, the valve must pass the applicable pressure testing prior to installation and service.

5.7 The gear box requires different grease, suitable for -20°C (-4°F) to 80°C (176°F), contact DHV for other grease applications.

5.8 If the gear operator is used frequently, the gear box grease should be replaced every three years. If used less frequently, it should be replaced every five years.

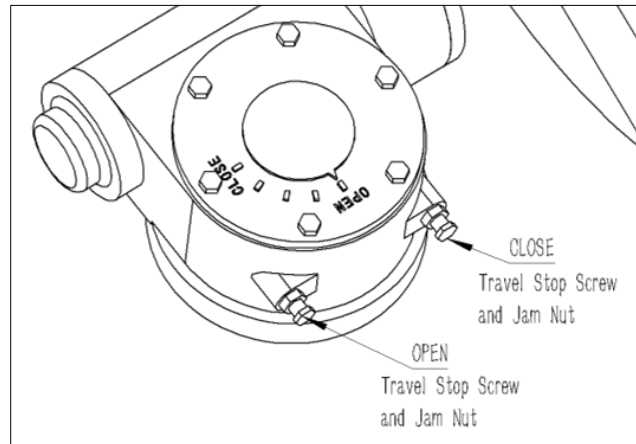

5.9 Gear box position stop calibration:

- 5.9.1** Install “CLOSE” position travel stop screw and jam nut as shown in illustrations above.
- 5.9.2** Operate the valve to the fully closed position until it engages with the travel stop screw.
- 5.9.3** Ensure the valve is completely closed against the stop, loosen the jam nut and turn the stop screw counter-clockwise 3-4 turns.
- 5.9.4** If medium is leaking from valve body cavity from any one side of valve, this may indicate the valve seat is leaking.
- 5.9.5** Turn the hand wheel clockwise to close the valve further until leaking has completely stopped. Continue turning the hand wheel slightly back and forth to determine the best closed position.
- 5.9.6** Once the leakage has completely stopped, turn the CLOSE position stop screw clockwise until it stops, then tighten the jam nut.
- 5.9.7** If leaking is still experienced after completing above steps, the seat sealing surface may be damaged and should be repaired or replaced.

5.10 At NO time shall any weld repair be conducted on the valve while in service. Never strike the valve with a hammer or other impact device. Ensure that no excess weight is placed on the valve that was not part of the original manufacture design.



WARNING ! ANY MAINTENANCE OR REPAIR MUST NOT OCCUR UNTIL THE VALVE BODY PRESSURE IS COMPLETELY RELEASED. NO REPAIR WORK WILL BE DONE WHILE THE VALVE IS UNDER PRESSURE.



6. DETAILED DISASSEMBLY AND ASSEMBLY

6.1 FLOATING BALL VALVE DISASSEMBLY

6.1.1 Precautions for dismantling:

- 6.1.1.1 The valve cavity should be completely depressurized. Even if the pressure in the distribution tube is discharged, there is residual pressure in the valve, and the valve must be opened and closed several times to ensure that the pressure in the cavity is completely released; After confirming there is no residual pressure, remove it from the pipeline.
- 6.1.1.2 When the medium used is harmful to the human body or flammable and explosive, no medium should remain in the valve (especially in the middle cavity). It should be fully filled with water and cleaned. After confirming that there is no residual fluid medium, remove it from the pipeline. At this point, several opening and closing operations can be performed for better results.
- 6.1.1.3 Since the medium transported by the valve may be harmful to the human body or flammable and explosive, and to avoid injury caused by valve parts during assembly, please take necessary protective measures (such as protective masks, gloves, etc.) when performing valve disassembly operations, and fire must be prohibited at the disassembly site.
- 6.1.1.4 The dismantled parts should be handled gently and placed on a soft pad, and it is strictly prohibited for the parts (especially the sealing surfaces) come into direct contact with the hard ground.
- 6.1.1.5 Disassembled parts should be stored indoors and protected against rust if they are not used for a long time.

6.1.2 Disassembly process:

- 6.1.2.1 Remove the handle and take out the elastic stop ring and limit block.
- 6.1.2.2 Loosen the gland bolts and remove the gland and the packing.
- 6.1.2.3 Loosen the connecting nut on the valve cover, remove the valve cover, and take out the valve stem, valve stem bearing, and thrust bearing.
- 6.1.2.4 Loosen the connecting nut and remove the connecting body and back cover.
- 6.1.2.5 Remove the ball from the upper part of the valve body.
- 6.1.2.6 Remove the valve seat, valve seat seal, and gasket from the coupling and rear cover.
- 6.1.2.7 Remove all the connection bolts from the valve body.

6.2 FLOATING BALL VALVE ASSEMBLY

6.2.1 Precautions during assembly:

- 6.2.1.1 The assembly environment and each component must be cleaned and free from attachments such as iron filings, rust, and welding slag before assembly. It must be that there are no scratches on the surfaces of the ball, valve seat sealing part, and the rotating part of the valve stem. The surfaces at the mating points the valve body, connection body, and valve cover must not have any scratches.
- 6.2.1.2 The cleanliness of the assembly environment and all components must be maintained throughout the assembly process; during assembly, the ground must be padded with soft mats, it is strictly prohibited for all components and the assembled valve products to come into direct contact with the hard ground;
- 6.2.1.3 During assembly, excessive force should be avoided when striking valves and related components to prevent damage or deformation.

6.2.2 Assembly process

- 6.2.2.1 Tighten the connecting bolts into the valve body.
- 6.2.2.2 Install the valve stem bearing and thrust bearing on the valve stem.
- 6.2.2.3 Insert the seat into the connector and rear cover.
- 6.2.2.4 Put the ball into the valve body, rotate the ball 90 degrees through the tooling, and ensure that the ball flow orifice is parallel to the valve body joint.
- 6.2.2.5 Insert the stem and match it to the flat groove of the sphere, noting that the mark on the top of the stem matches the position of the flow hole of the sphere.
- 6.2.2.6 Put the valve seat into the connector and the back cover, put the joint gasket into the concave stop of the valve body, and close the connector and the back cover.
- 6.2.2.7 Tighten the flange connecting nut of each joint relatively evenly.
- 6.2.2.8 Place the joint gasket in the concave stop of the upper part of the valve body, the valve stem through the valve cover, and close the valve cover and the valve body, and tighten the valve cover connecting nut relatively evenly.
- 6.2.2.9 Load the filler and the filler gland in turn on the valve stem, screw in the filler gland bolt, tighten it by hand, and then properly tighten it with a tool, and then load the limit block, elastic stop ring, handle, etc.

Note: When tightening the gland bolts, do not tighten one first and then the other, as this will cause the packing to be skewed and lead valve leakage. The correct method is to slightly tighten one first, then the other, and repeat this process until the packing and gland are



securely tightened.



WARNING! DO NOT DAMAGE THE BALL, SEAT, OR SEALING SURFACE

7. TROUBLESHOOTING

TROUBLE	PROBABLE CAUSE	REMEDY
Seat leakage at closed position	Ball sealing surface damaged	Repair or replace the ball
	Seat or Seat insert damaged	Replace the seat
	Ball not completely closed	Check the valve CLOSED indicator on the gear box
	Gear box / actuator not adjusted correctly	Adjust the timing on the gear box or actuator
Ball operation is not smooth	Possible foreign object between ball and seat or ball and body cavity.	Clean ball and cavity area using injectable sealant, or disassemble and clean
		Clean ball and seat sealing surface using injectable sealant, or disassemble and clean
Valve is difficult to operate or the torque is too high	Damaged valve seat	Replace the valve seat, for temporary use, inject a sealant
	Valve internal pressure or temperature may be too high	Ensure pressure/temperature are within stated limits
	Foreign objects are trapped inside the body cavity	Clean the valve internals by injecting valve cleaner, or disassembly
Leakage at stem	Flange bolts are loose	Tighten bolts
	Stem sealing surface or valve itself is damaged	Repair or replace the valve stem
	Stem sealing parts are damaged	Replace stem sealing parts
	Pipe threads are not tight or damaged	Tighten the pipe threads or replace the pipe
Leakage from pipe	Pipe has foreign objects inside	Clean the pipe and remove any foreign objects
	Pipe threads are damaged	Install temporary pipe seals and replace the pipe once the process is shut down.



8. WARRANTY AND SERVICE

8.1 VALVE WARRANTY PERIOD

8.1.1 Valve warranty period is 12 months from the date shipped from the factory.

8.1.2 In the event the end user encounters an issue of quality, please notify DHV immediately. DHV reserve the right to investigate and settle all issues of quality concerns directly with the end user. Refer to DHV's standard warranty policies for questions or concerns regarding warranty concerns.

8.1.3 Addressing a valve quality issue within the warranty period:

DHV reserves the right to review and respond to all requests for warranty repair or replacement, prior to making any replacement or repairs by the end user.

8.1.4 DHV will not be held responsible for any damage due to natural disaster, such as earthquake, hurricane etc. during valve shipment.

8.1.5 DHV must to be consulted for any warranty issue before being held responsible for any repairs or valve replacement.

8.2 SERVICE

8.2.1 If required by the contract, DHV may provide and perform field installation and start up testing.

8.2.2 Upon end user request, DHV can provide services in monitoring the valve quality and history for Long Term Ownership. Additionally, DHV can provide all the necessary training of repair services to the valve, as well as training on safe valve operations.



APPENDIX I – INSTALLATION REQUIREMENTS

Installation Requirements for DHV brand Ball Valves

Assembly

Includes all non DHV branded hand levers, gearboxes, or actuators.

- Gearboxes, actuators and necessary adapters must conform to the valve’s ISO pad top work design.
- It is important that adapter plates and gears should be bolted to the valve’s top work plate using the correct bolt size, torque, and tightening pattern.
- Care should be taken at all times to protect the stem from any movement, stress, force or other potential damage while ensuring the stem remains centered in the valve mounting flange during installation.

Operation

- Personnel installing the operator must ensure there is no abnormal stem movement or run out during operation.
- It is extremely important that all “stops” and or “limits” are correctly set to prevent damage or unnecessary wear to the valve.

Testing

Applies to all methods of hydro testing and pre-commissioning testing.

- Procedures must be compliant to API specifications.
- Always ensure any vents or drains opened during the testing process are securely closed upon completion of the test.

Installation

- Ball valves are best suited for operation in the horizontal position.
- Ball valves must always be either fully open, or fully closed once installed and are not designed or intended for throttling applications.

Shipping

Valves need to be fully open during shipment and actuators need to be braced to support the extra weight at the top end of the valve.

Failure to follow these manufacturer prescribed requirements will void any warranties



DHV Industries, Inc.

3451 Pegasus Drive

Bakersfield, CA 93308 USA

Call Toll Free: (833) DHV-USA1

Phone: (661) 392-8948

Fax: (661) 392-8947

E-mail: sales@dhvindustries.com

Website: www.dhvindustries.com

DHV Valve Canada Co., Ltd

100, 3060 12 Street

Nisku, Alberta, T9E 0S2 Canada

Phone: (780) 669-9420

E-mail: sales@dhvindustries.com

Website: www.dhvindustries.com

DHV is committed to providing you with the necessary information to support our products. Our global network of authorized service centers, technical support personnel and warranty support personnel are ready to serve your needs for support on applications, products, service and warranty. Contact our USA Bakersfield headquarters for immediate assistance to your support needs.